

PART NUMBER CREATOR

6 S T F 0 9 P A M 0 4 B 3 O X

Product Line

- 4* = Shell brass tin plated with plastic frame or without frame
- 6 = Shell brass tin plated with metal frame (Standard) (*on request)

Variations

- STF = D-Subminiatur Standard filtered
- HDF = D-Subminiatur High Density filtered

No. of pos. for STF

- 09 = 09 pos.
- 15 = 15 pos.
- 25 = 25 pos.
- 37 = 37 pos.
- 50 = 50 pos.

No. of pos. for HDF

- 15 = 15 pos.
- 26 = 26 pos.
- 44 = 44 pos.
- 62 = 62 pos.
- 78 = 78 pos.

P = Plug connector (Standard)

(Socket connector on request)

Quality class / Plating code for contacts

- A = Quality class 3 = 50 mating cycles
- B = Quality class 2 = 200 mating cycles
- C = Quality class 1 = 500 mating cycles

Termination

- M = Solder cup only for STF
- R = Solder pin, straight
- T = Solder pin, angled, .189" / 4.80 mm only for STF
- U = Solder pin, angled, .276" / 7.00 mm only for STF
- Z = Solder pin, angled, .465" / 11.80 mm only for STF
- Y = Solder pin, angled, .220" / 5.60 mm only for HDF

Capacitance

- 01 = 180 pF ± 20% tolerance
- 03 = 370 pF ± 20% tolerance
- 04 = 830 pF ± 20% tolerance
- 05* = 1300 pF ± 20% tolerance *not applicable for HDF

Mounting style

- A1 = Riveted through hole for cable mount / Shell without sealing frame
- B2 = M3 threaded insert
- B3 = 4-40 UNC threaded insert
- B4 = Threaded lock for M3 front mounting
- B5 = Threaded lock for 4-40 UNC front mounting
- E1 = M3 threaded rear spacer with PCB clip, PCB .063" / 1.60 mm
- E2 = 4-40 UNC threaded rear spacer with PCB clip, PCB .063" / 1.60 mm
- S1 = Metal bracket, M3 threaded insert
- S2 = Metal bracket, 4-40 UNC threaded insert
- S3 = Metal bracket, M3 threaded insert and PCB clip
- S4 = Metal bracket, 4-40 UNC threaded insert and PCB clip
- R1 = Metal bracket, M3 threaded insert
- R2 = Metal bracket, 4-40 UNC threaded insert
- R3 = Metal bracket, M3 threaded insert and PCB clip
- R4 = Metal bracket, 4-40 UNC threaded insert and PCB clip

OX = Standard

TECHNICAL DATA

Materials	Filter D-SUB Standard 9, 15, 25, 37 and 50 position	Filter D-SUB High Density 15, 26, 44, and 62 position
Insulator	Polyester GF UL94 V-0	
Contacts	CU alloy	
Contact plating	Gold plated over nickel, solder area tin plated	
Shell	Brass tin plated / Stainless steel	
Mechanical and electrical characteristics		
Dielectric with standing voltage	Standard 424 VDC	Standard 300 VDC
Working voltage	100 VDC Depending on isolation coordination (refer to DIN VDE 0110/IEC 664-1)	100 VDC
Contact resistance	Max. 10 mΩ prior to stressing, Δ R max. 10 mΩ after stressing per DIN 41652, Part 2	
Insulation resistance	≥ 1GΩ	
Current rating	7.5 A (UL) / 5 A (CSA, VDE)	3 A (UL, VDE) / 2.5 A (CSA)
Voltage surge 10/700μs	Standard 300 V	Standard 300 V
Temperature working range	-25°C to +105°C	-25°C to +85°C
Capacitor values For other capacitance values please contact the factory.	180 pF ± 20% tolerance 370 pF ± 20% tolerance 830 pF ± 20% tolerance 1300 pF ± 20% tolerance	180 pF ± 20% tolerance 370 pF ± 20% tolerance 830 pF ± 20% tolerance
Mating and unmating forces	9 pos. ≤ 30 N 15 pos. ≤ 50 N 25 pos. ≤ 83 N 37 pos. ≤ 123 N 50 pos. ≤ 167 N	15 pos. ≤ 50 N 26 pos. ≤ 84 N 44 pos. ≤ 120 N 62 pos. ≤ 170 N
Quality class	A = Quality class 3 = 50 mating cycles B = Quality class 2 = 200 mating cycles C = Quality class 1 = 500 mating cycles	
Degree of protection	Requirement according to IEC 60529 – IP67	

Technical alterations are subject to change without notice.

IP-CODE DEFINITIONS

1. Code figure	Definition	Remark
0	Not protected	
1	Protected against access to hazardous parts by the back of the hand. Protected against fixed foreign objects $\varnothing \geq 1.969'' / 50 \text{ mm}$.	
2	Protected against access to hazardous parts with a finger. Protected against fixed foreign objects $\varnothing \geq .492'' / 12.5 \text{ mm}$.	
3	Protected against access to hazardous parts with a tool. Protected against fixed foreign objects $\varnothing \geq .098'' / 2.5 \text{ mm}$.	
4	Protected against access to hazardous parts with a wire. Protected against fixed foreign objects $\varnothing \geq .039'' / 1 \text{ mm}$.	
5	Protected against access to hazardous parts with a wire. Dust protected.	Ingress of dust is not completely blocked. But dust may not penetrate to the extent that satisfactory operation of the device or safety is impaired.
6	Protected against access to hazardous parts with a wire. Dustproof. No ingress of dust.	

2. Code figure	Definition	Remark
0	Not protected	
1	Protected against dropper.	
2	Protected against dropper when the shell is tipped as much as 15°.	
3	Protected against spray water	Up to 60° of either side of the vertical, such spray water shall have no harmful effects.
4	Protected against splash water	On the shell from all directions, no harmful effects shall be incurred.
5	Protected against jets of water.	
6	Protected against strong jets of water.	
7	Protected against the effects of temporary submersion in water.	Water may not ingress in a volume that would cause harmful effects when the shell is submerged in water for 30 min at a depth of 1 m.
8	Protected against the effects of continuous submersion in water.	Water may not ingress in a volume that would cause harmful effects when the shell is continuously submerged in water under conditions agreed between manufacturer and user. However, these conditions must be more stringent than those described under code figure 7.
9k	Protected against water from high-pressure or steam cleaning.	

Explanation to spray water protected (IP) systems and their environment.

This system, described in IEC 60529, was developed to represent standard values for respective protection:

- a) Contact with, and ingress of, fixed foreign objects
- b) The ingress of liquids to which the inside is to be exposed.

The first digit describes the level of protection for life, contacting objects and the intrusion of foreign bodies. The second digit describes the level of protection against the ingress of liquids. The larger the first and second digits are, the greater afforded protection is, e.g. IP55 must also meet the requirements of all lower protection levels, such as IP22, IP23, IP34 and IP54.

MATING CONDITIONS

Float mount tolerance guide

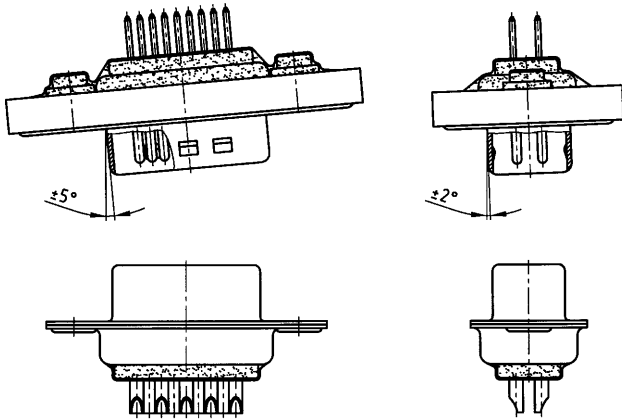

Rigid mount tolerance guide

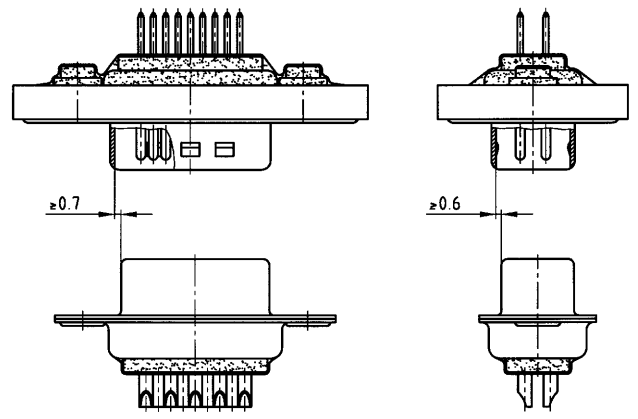

Rigid mount vertical to tolerance guide

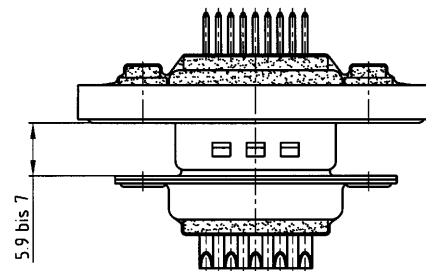

PANEL CUT-OUT

Rear panel mounting

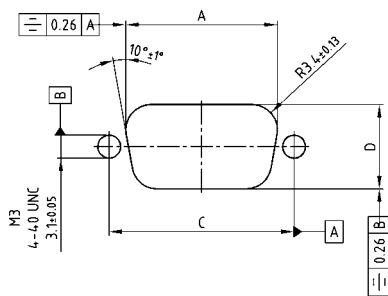

Front panel mounting

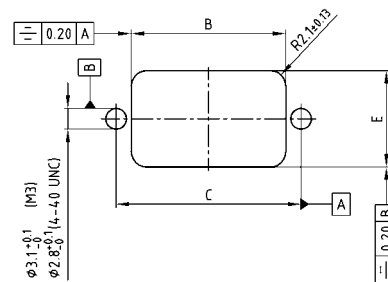

Shell size	A ± 0.1	B ± 0.1	C ± 0.1	D ± 0.1	E ± 0.1
9	20.50	20.90	25.00	11.40	13.00
15	28.80	29.20	33.30	11.40	13.00
25	42.50	42.90	47.04	11.40	13.00
37	59.10	59.40	63.50	11.40	13.00
50	56.30	57.00	61.10	14.10	15.80

PANEL CUT-OUT

FRONT PANEL MOUNTING

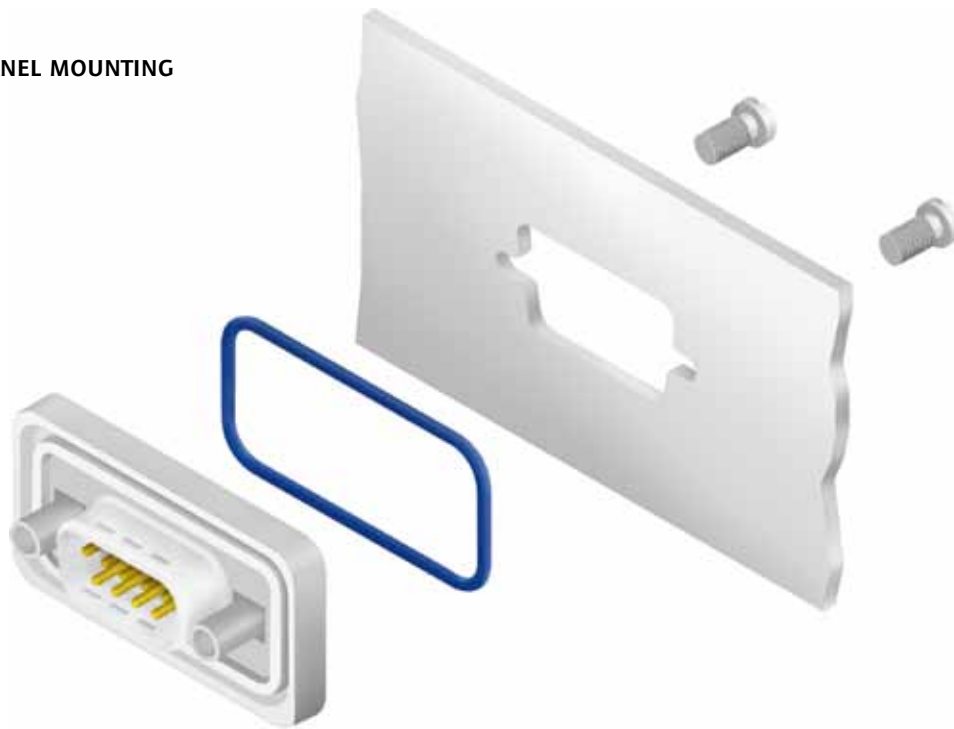

REAR PANEL MOUNTING



The hex bolts illustrated here (4-40 UNC or M3 threads) are included in the delivery complement of every connector with a sealing frame. The length of this spacer has been selected to accommodate a panel thickness of .063"/1.6 mm such that it does not extend beyond the plug-in height. Furthermore, the hex bolts outside threads are shorter than standard hex bolts. Material: stainless steel.

INSERTION LOSS

C-FILTER WITH PLANAR FILTER TECHNOLOGY

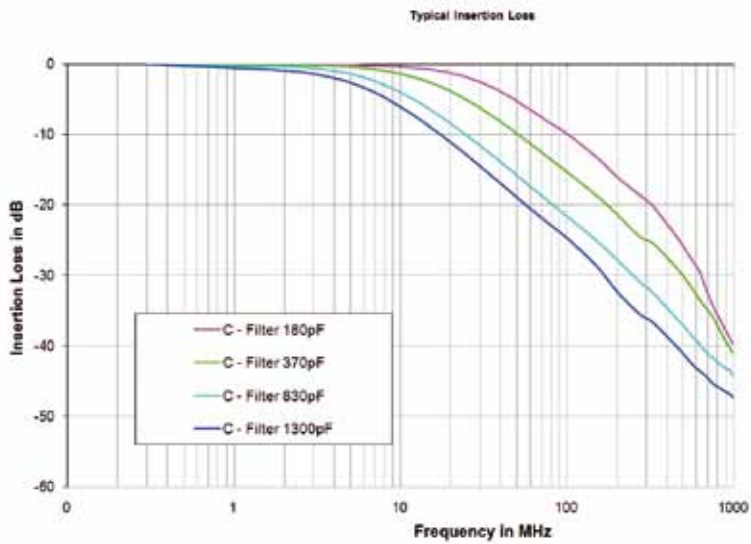

SOLDER PROFILE

Connector Type	Preheating		Solder terminal dipping parameters	
	max. Temperature	Duration	max. Solder bath Temperature	max. Terminal Immersion Time
Filter D-SUB	100°C	30s	260°C	5s
Combo D-SUB Filter	120°C	120s	260°C	5s
Filter D-SUB Water Resistant	100°C	30s	240°C	5s
Combo D-SUB Water Resistant	120°C	120s	240°C	5s
D-SUB Water Resistant	120°C	120s	240°C	5s
D-SUB Solid Body Type Water Resistant	150°C	180s	265°C	8s
RJ45 Modular Jack Filtered	150°C	180s	265°C	8s
Filter Plates	150°C	180s	265°C	8s

Recommended wave-solder parameters for CONEC connectors.

PCB LAYOUT, D-SUB HIGH DENSITY

Solder pin, angled, .220" / 5.6 mm – Plug connector

15 POS.

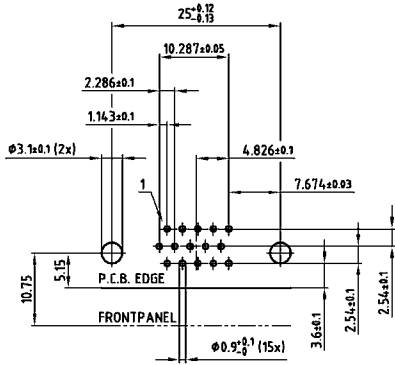

78 POS.

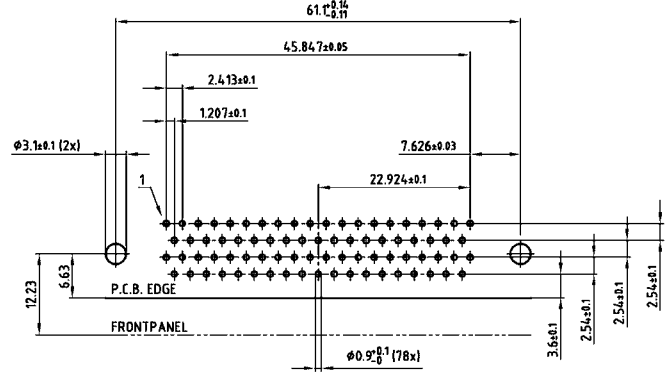

26 POS.

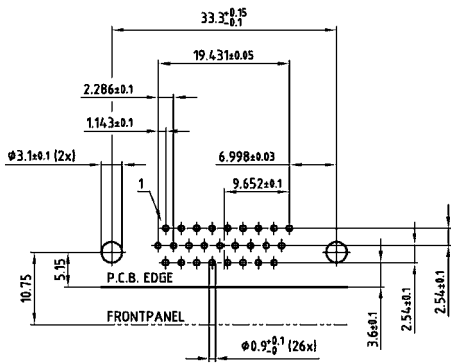

62 POS.

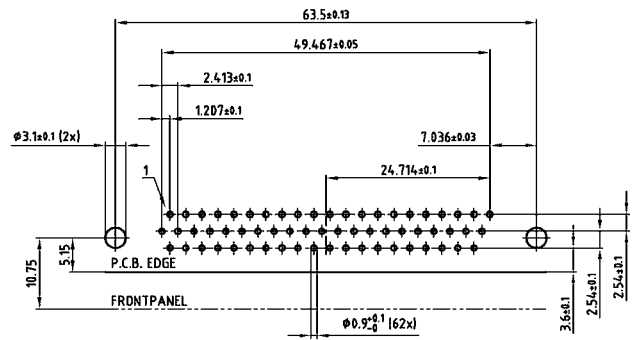

44 POS.

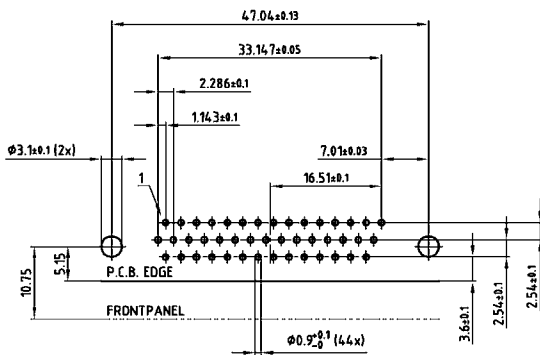

PCB layout Kat1kGWA (View: component side)