

# MATING CONDITIONS

Float mount tolerance guide

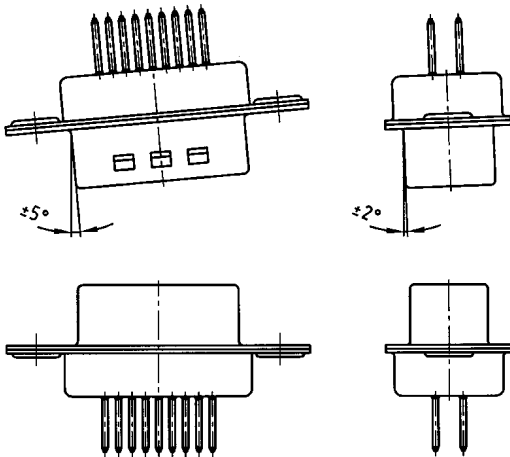

Rigid mount tolerance guide

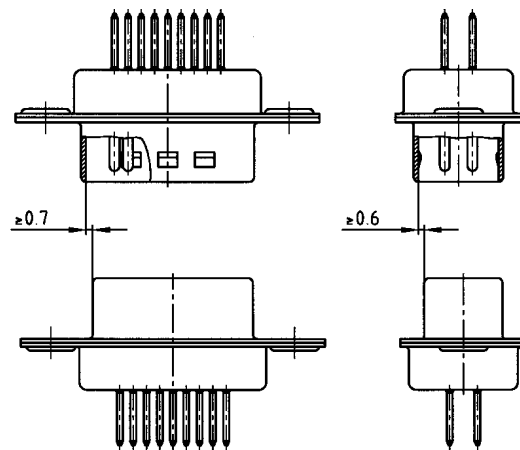

Rigid mount vertical to tolerance guide

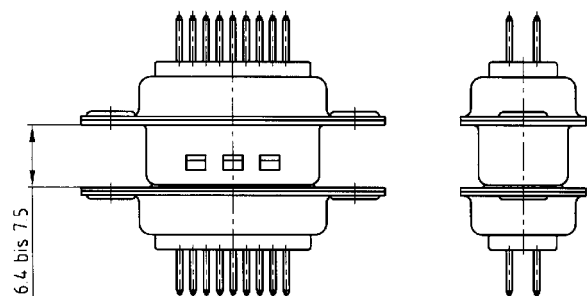

## PANEL CUT-OUT

Rear panel mounting

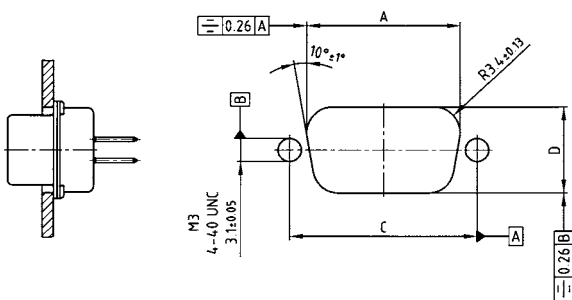

Front panel mounting

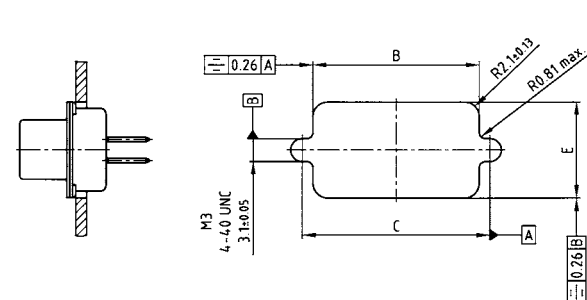

Shell size	A ± 0,13	B ± 0,13	C ± 0,13	D ± 0,13	E ± 0,13
9 15	20.50	22.20	25.00	11.40	13.00
15 26	28.80	30.50	33.30	11.40	13.00
25 44	42.50	44.30	47.04	11.40	13.00
37 62	59.10	60.70	63.50	11.40	13.00
50 78	56.30	58.30	61.10	14.10	15.80

# PART NUMBER CREATOR

**2 4 1 A 1011 O X**

**Product Line**

**Design**

- 1 = Plug connector, standard DWV
- 2 = Socket connector, standard DWV
- 5 = Plug connector, high DWV
- 6 = Socket connector, high DWV
- 7\* = Plug connector, ultra high DWV
- 8\* = Socket connector, ultra high DWV

\*on request

**Quality class for contacts**

- A = Quality class 3 / 50 mating cycles
- B = Quality class 2 / 200 mating cycles
- C = Quality class 1 / 500 mating cycles

**Serial number**

**Design**

- OX = Standard design

**Filter connectors for higher DWV**

Increasing requirements, with respect to higher DWV for filter connectors, have induced us to carry out advanced development in this direction. CONEC is capable of delivering filter connectors with DWV of 1500 VDC.

The various DWV ratings are as follows:

- 1 Standard DWV .....300/424 VDC
- 2 High DWV.....707 VDC
- 3 Ultra high DWV.....1000/1500 VDC (on request)

Furthermore, the filter connector can be designed for ultra high DWV of up to 2500 VDC at 10/700 pulse voltage. Filter connectors so designed fulfill the standards established according to CE requirements, i.e. 1414 VDC. For example, capacity ratings range from 180 pF to 1300 pF for standard series.

For special capacitance values consult factory.

# TECHNICAL DATA

Materials	Filter D-SUB Standard 9, 15, 25, 37 and 50 position	Filter D-SUB High Density 15, 25, 44, 62 and 78 position
Insulator	Polyester GF UL94 V-0	
Contacts	CU alloy	
Contact plating	Gold plated over nickel, solder area tin plated	
Shell	Steel tin plated / brass tin plated	
Mechanical and electrical characteristics		
Dielectric with standing voltage	<ul style="list-style-type: none"> <li>• Standard 424 VDC</li> <li>• Standard 300 VDC (for .T-Filter)</li> <li>• High DWV 707 VDC</li> <li>• Ultra high DWV 1500 VDC*</li> <li>• Ultra high DWV 1000 VDC* (for .T-Filter) *on request</li> </ul>	<ul style="list-style-type: none"> <li>• Standard 300 VDC</li> </ul>
Working voltage	<ul style="list-style-type: none"> <li>• Standard 100 VDC*</li> <li>• High DWV 100 VDC*</li> <li>• Ultra high DWV 200 VDC*</li> </ul> *Depending on isolation coordination (refer to DIN VDE 0110/IEC 664-1)	<ul style="list-style-type: none"> <li>• Standard 100 VDC*</li> </ul>
Contact resistance	Max. 10 mΩ prior to stressing, Δ R max. 10 mΩ after stressing per DIN 41652, Part 2	
Insulation resistance	≥ 1GΩ	
Current rating	7.5 A (UL) / 5 A (CSA,VDE)	3 A (UL,VDE) / 2.5 A (CSA)
Voltage surge 10/700μs	Standard 300 V High Voltage 500 V	Standard 300 V
Mating and unmating forces	9 pos. ≤ 30 N 15 pos. ≤ 50 N 25 pos. ≤ 83 N 37 pos. ≤ 123 N 50 pos. ≤ 167 N	15 pos. ≤ 50 N 26 pos. ≤ 83 N 44 pos. ≤ 110 N 62 pos. ≤ 170 N
Temperature working range	-25°C to +105°C	-25°C to +85°C
Humidity	40°C / 85% relative humidity/RH	
Capacitor values For other capacitance values please contact the factory.	180 pF ± 20% tolerance 370 pF ± 20% tolerance 830 pF ± 20% tolerance 1300 pF ± 20% tolerance other capacitor values on request	180 pF ± 20% tolerance 370 pF ± 20% tolerance 830 pF ± 20% tolerance
Quality class	A = Quality class 3 = 50 mating cycles B = Quality class 2 = 200 mating cycles C = Quality class 1 = 500 mating cycles	

Technical alterations are subject to change without notice.

# INSERTION LOSS

## C-FILTER WITH PLANAR FILTER TECHNOLOGY

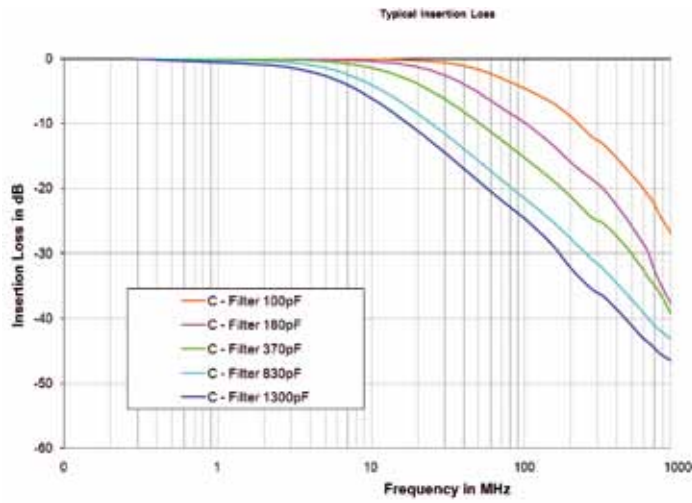

## C-FILTER WITH CHIP TECHNOLOGY

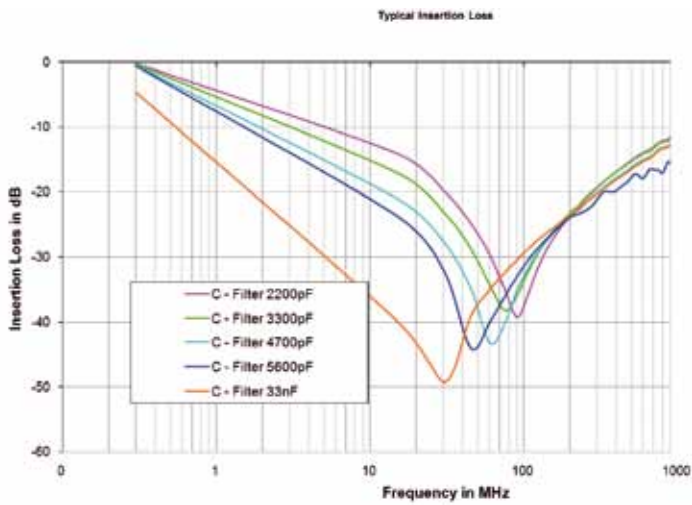

## LC-FILTER WITH PLANAR FILTER TECHNOLOGY

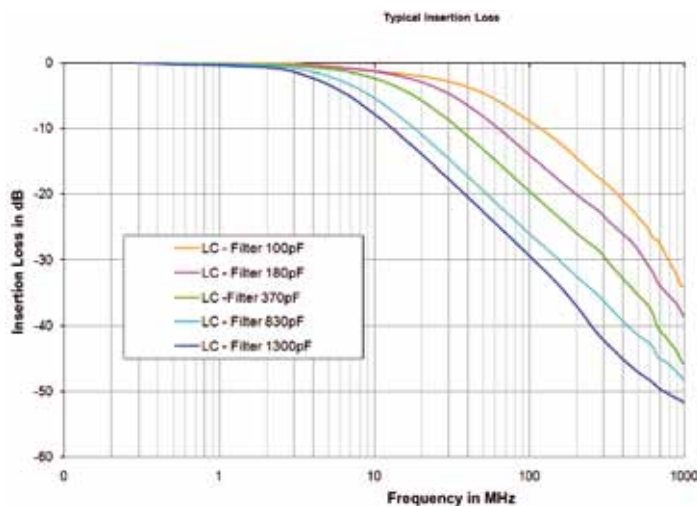

# INSERTION LOSS

## π-FILTER WITH PLANAR FILTER TECHNOLOGY

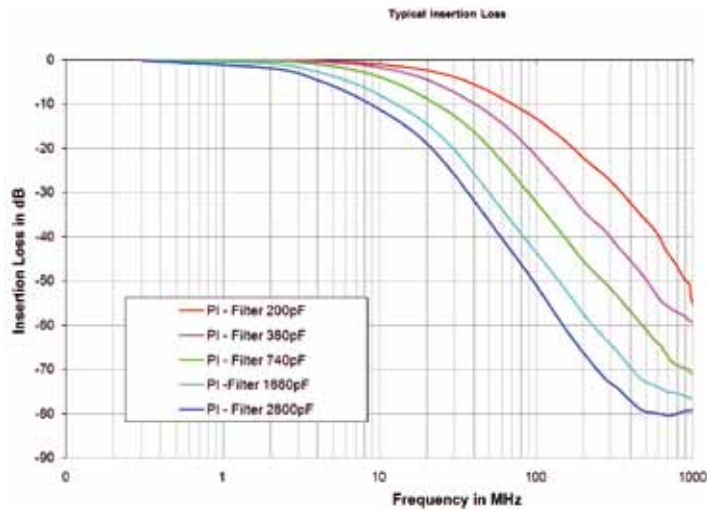

# SOLDER PROFILE

Connector Type	Preheating		Solder terminal dipping parameters	
	max. Temperature	Duration	max. Solder bath Temperature	max. Terminal Immersion Time
Filter D-SUB	100°C	30s	260°C	5s
Combo D-SUB Filter	120°C	120s	260°C	5s
Filter D-SUB Water Resistant	100°C	30s	240°C	5s
Combo D-SUB Water Resistant	120°C	120s	240°C	5s
D-SUB Water Resistant	120°C	120s	240°C	5s
D-SUB Solid Body Type Water Resistant	150°C	180s	265°C	8s
RJ45 Mod. Jack Filtered	150°C	180s	265°C	8s
Filter Plates	150°C	180s	265°C	8s

Recommended wave-solder parameters for CONEC connectors.

# PCB LAYOUT, D-SUB STANDARD

Solder pin, angled, .370" / 9.4 mm – Socket connector

9 POS.

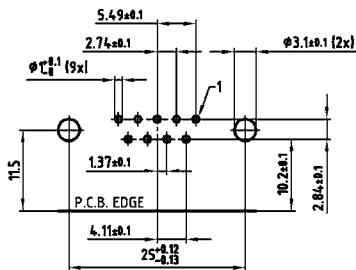

37 POS.

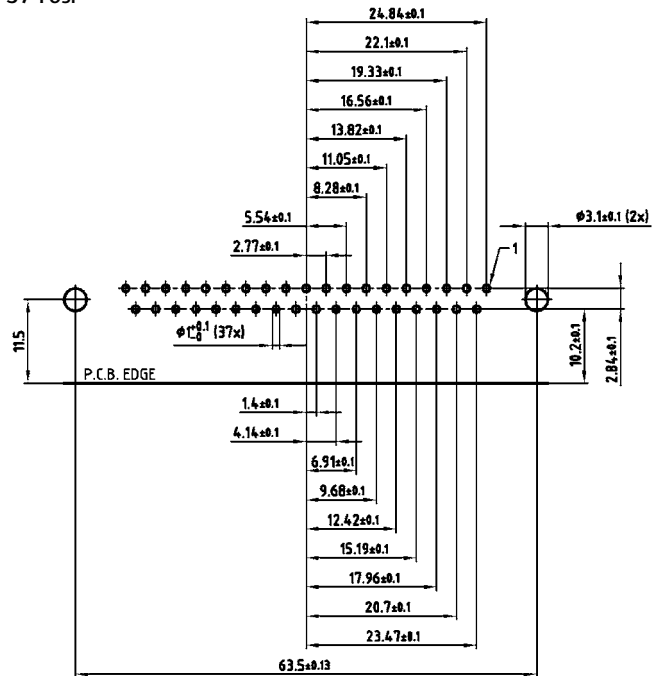

15 POS.

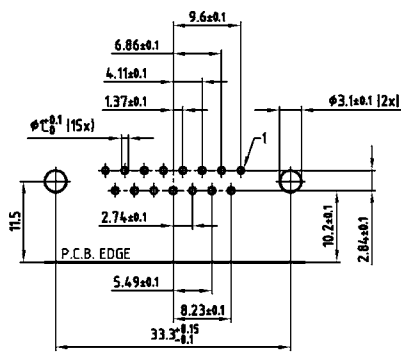

50 POS.

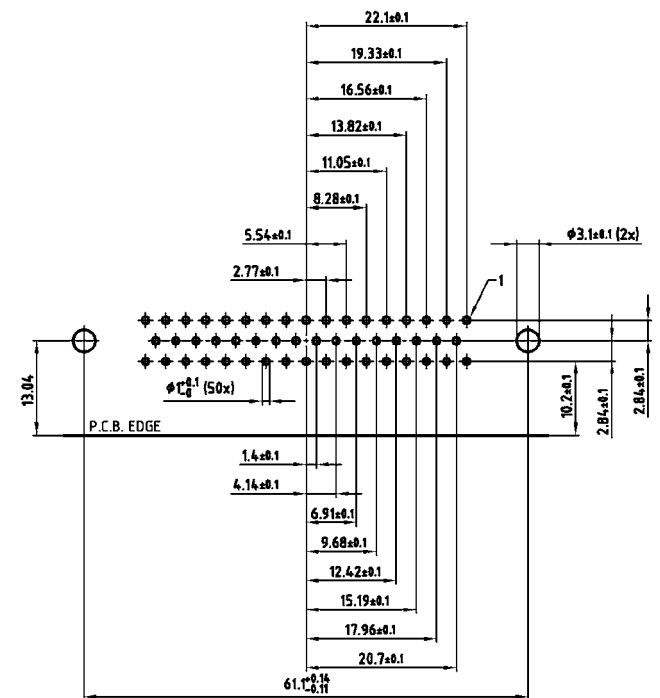

25 POS.

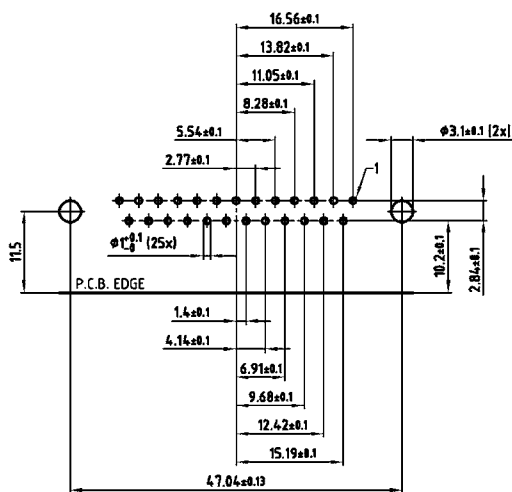

PCB layout Kat1 kGGA (View: component side)

# PCB LAYOUT, D-SUB STANDARD

Solder pin, angled, .370" / 9.4 mm – Plug connector

9 POS.

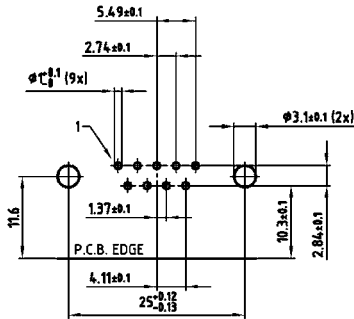

37 POS.

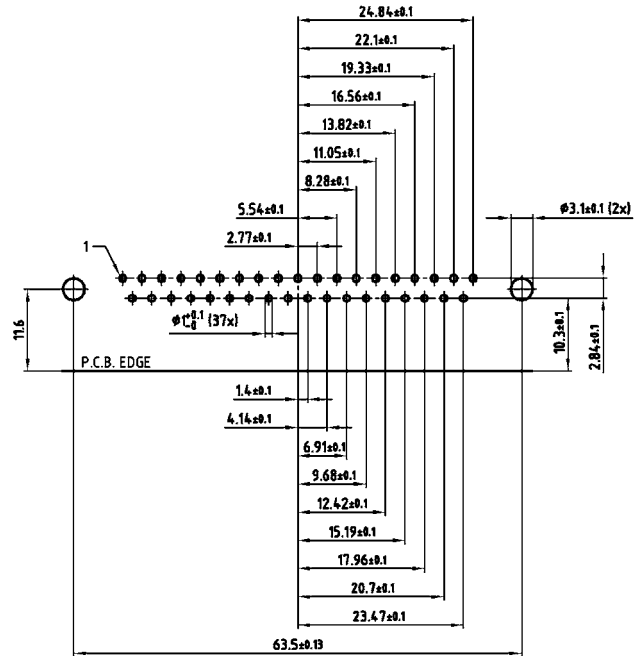

15 POS.

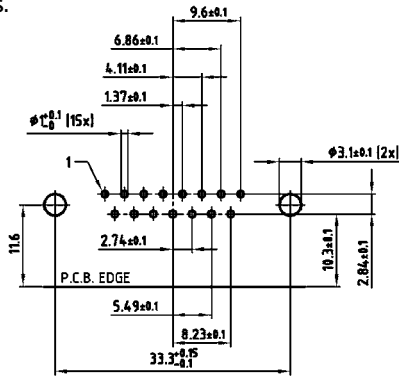

50 POS.

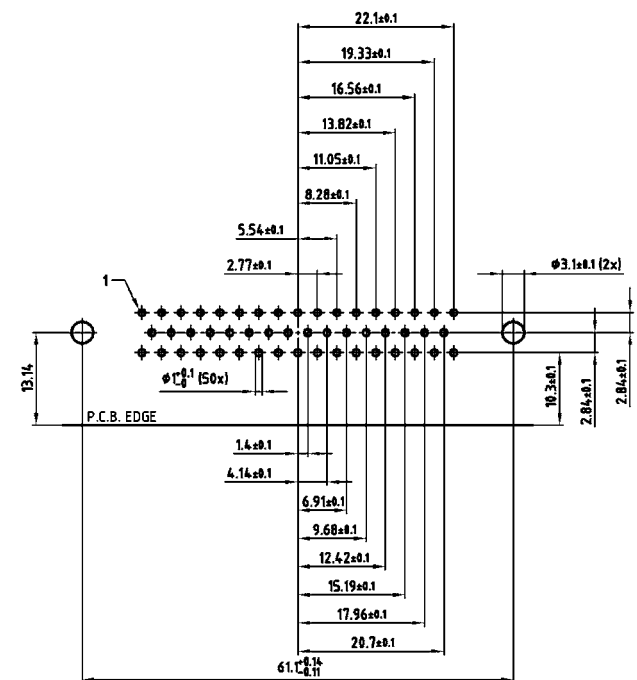

25 POS.

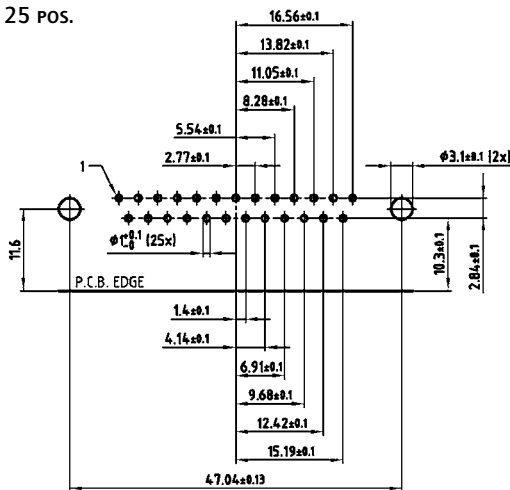

PCB layout Kat1kGHA (View: component side)